

**BEST OF  
CLASS**



The Jewell LSO Series Inclinometer with 4 to 20 mA output is a  $\pm 1.0$  to  $\pm 90$  device designed for applications where high levels of shock, vibration and electrical noise are present and/or long cable runs are required.

### LSOC/P Series Flexure Suspension Servo Fluid Damped Inclinometer Specifications

#### Performance

Input Range, ° (Note 1)	$\pm 1.0$	$\pm 14.5$	$\pm 30$	$\pm 90$
Full Range Output (FRO), mADC $\pm 1.0\%$	4 to 20	4 to 20	4 to 20	4 to 20
Nonlinearity, % FRO max (Note 2)	0.05	0.10	0.10	0.05
Scale Factor, mA/g nominal	458	31.3	16.0	8.0
Scale Factor Temp Sens, PPM/°C max	400	100	100	100
Natural Frequency, Hz nominal (Note 3)	0.3	15	20	30
Bandwidth (-3dB), Hz nominal	0.3	15	20	30
Input Axis Misalignment, ° max	0.15	0.50	1.00	1.00
Output at Zero Tilt, mA	12 $\pm$ 0.6	12 $\pm$ 0.3	12 $\pm$ 0.3	12 $\pm$ 0.3
Zero Tilt Temp Sens, mA/°C max	0.015	0.0032	0.0032	0.0016
Resolution and Threshold, $\mu$ rad max	1	1	1	1

#### Electrical

Input Voltage, VDC	20 to 30 (24 nominal)
Input Current	40 mA maximum
Noise, mA rms max	0.01

#### Environmental

Operating Temp Range	-18 to +71°C
Survival Temp Range	-40 to +71°C
Vibration	20 grms
Shock	1500g, 0.5 msec, ½ sine
Seal	MIL-STD 202, Method 112

**NOTE 1:** Full Range is defined as "from negative full input angle to positive full input angle."

The Inclinometer output is proportional to the sine of the tilt angle.

**NOTE 2:** Referenced to theoretical sine value independent of misalignment.

**NOTE 3:** Output phase angle = -90°.

#### Applications

- Paving Machine Control
- Sluice Gate Control
- Continuous Casting

*LSOC/P Series 4-20 mA Output  
Flexure Suspension Servo Fluid Damped Inclinometer*

## Block Diagram

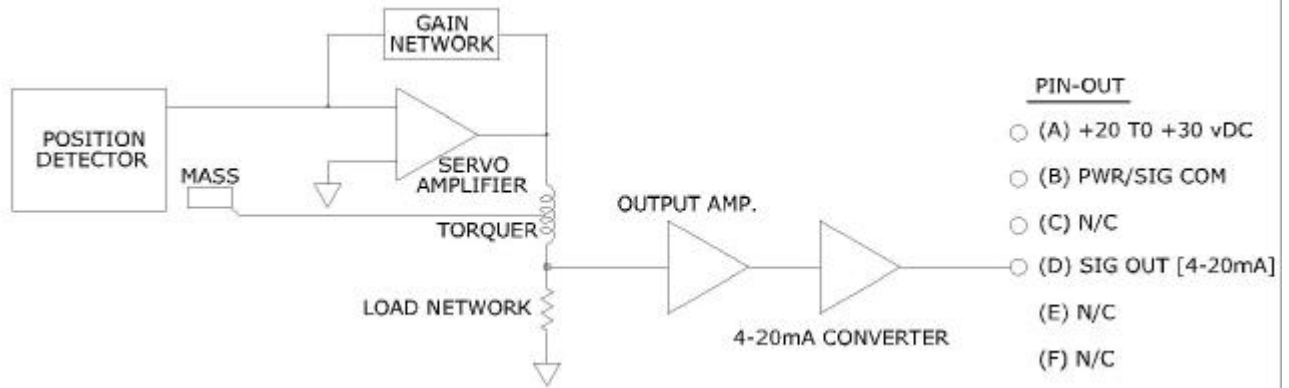

## Outline Diagram

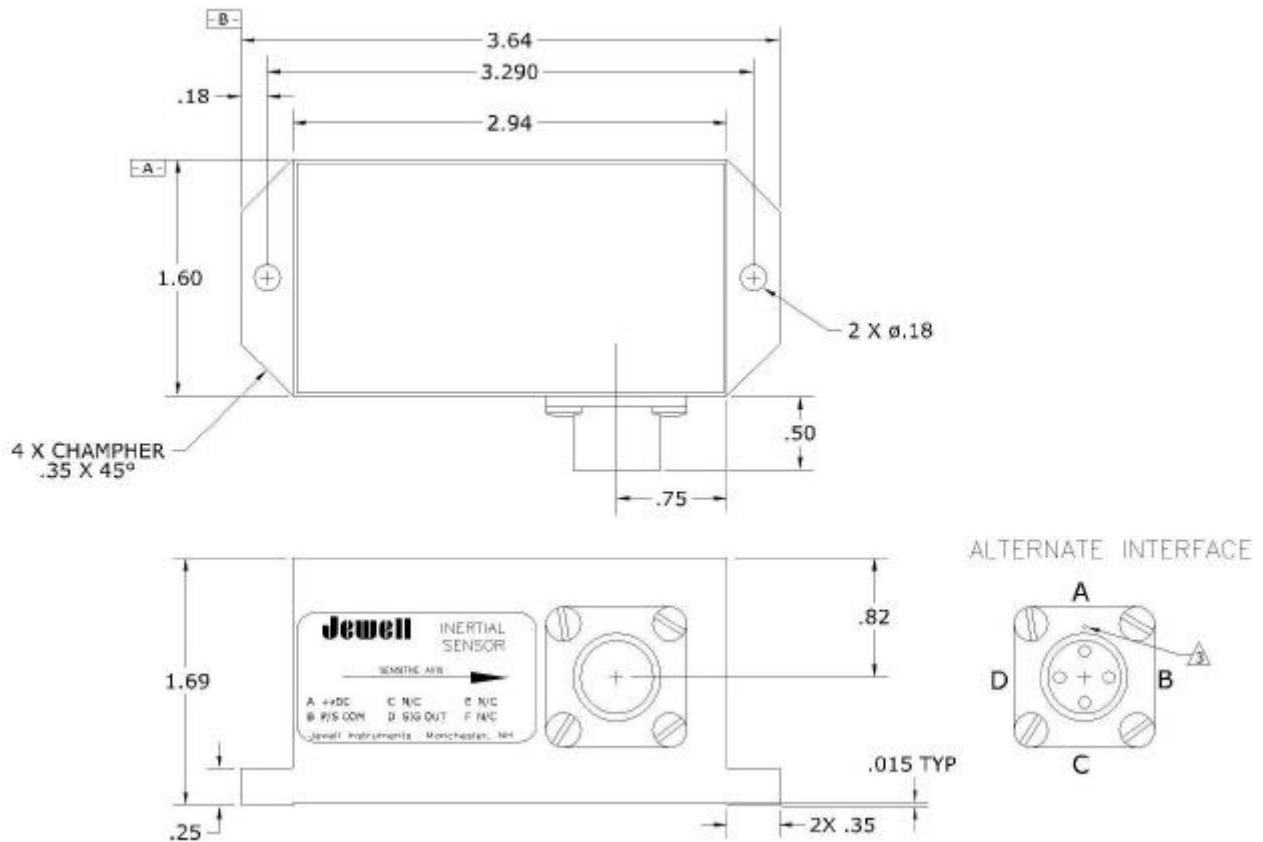

- 1 - DATUMS **A** AND **B** ARE DEFINED AS REFERENCE SURFACES
- 2 CONNECTOR SHALL BE PT02H-10-6P AND SHALL MATE WITH PT06A-10-6FR
- 3 DENOTES PIN A