

LCF 2000/3000 Inclinometer

**BEST OF
CLASS**



This is a two or three axis version of the rugged, high accuracy LCF Series. It is available with a wide range of options including single ended input power, internal temperature sensor and 4-20mA output

LCF 2000/3000 Inclinometer Specifications

Performance

Input Range, °:	±1.0	±14.5	±30.0	±90.0
Full Range Output (FRO), VDC ±1% ¹ :	±5.0	±5.0	±5.0	±5.0
Nonlinearity, % FRO ² , maximum:	0.05	0.02	0.02	0.10
Scale Factor, volts/g nominal:	286.5	20.0	10.0	5.0
Scale Factor Temp Sensitivity, PPM/°C, maximum:	200	100	100	100
Natural Frequency, Hz, nominal ³ :	3.0	30.0	30.0	30.0
Bandwidth (-3db), Hz, nominal:	3.0	30.0	30.0	30.0
Input-Axis Misalignment, °, maximum:	0.25	0.50	1.00	1.00
Bias Volts, maximum:	0.75	0.075	0.050	0.050
0° Output Temp Sensitivity, volts/°C, maximum:	0.015	0.001	0.0005	0.0003
Resolution and Threshold:	1μradian			

Electrical

Input Voltage, VDC ⁴ :	±12 to ±18		
Input Current, mA, nominal:	Model 2000 - 30	Model 3000 - 45	
Output Impedance, ohms, nominal:	100		
Noise, mV rms, maximum:	0.002		

Environmental

Operating Temp Range:	-40° C to +80° C
Survival Temp Range:	-60° C to +90° C
Vibration:	20 grms
Shock:	1000 g, 0.001 sec
Seal:	MIL-STD 202, Method 112
Weight:	16.0 oz.

¹ Full Range is defined "from negative full input angle to positive full input angle."

² Nonlinearity is specified as deviation of output referenced to theoretical sine function value, independent of misalignment.

³ Output Phase angle = -90°.

⁴ Unit Power connections can be easily adapted for operations from single-ended, floating power supplies of 24 to 36 Volts DC.

Applications

- ▶ Antenna Leveling
- ▶ Weapons Platforms
- ▶ Barge & Offshore Platform Leveling & Control
- ▶ Torpedo Attitude Control

LCF 2000 and 3000 Models

Dimensional Drawing for the LCF Inclinometer (Inch/mm)

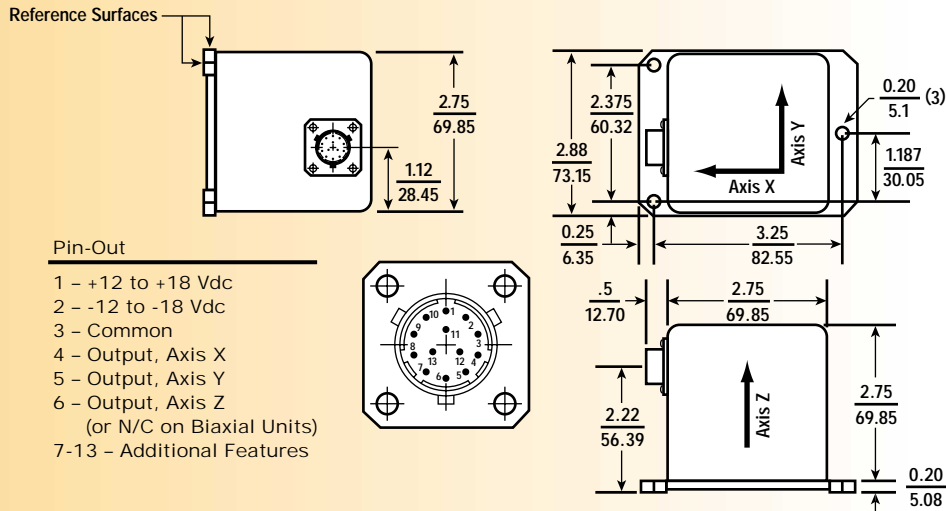

Block Diagram for the LCF Inclinometer

